

MOTOR SIEMENS 1LT2176-8 AA20-ZB3

Medidas	[mm]
A	310
B	360
C	170
K	2
Eje del conico D	50-60
E	140
rosca	30
H	225
chaveta	6 x15
Eje tras conico D	42,5-50
longitud	110
rosca	30
Chaveta	2x8

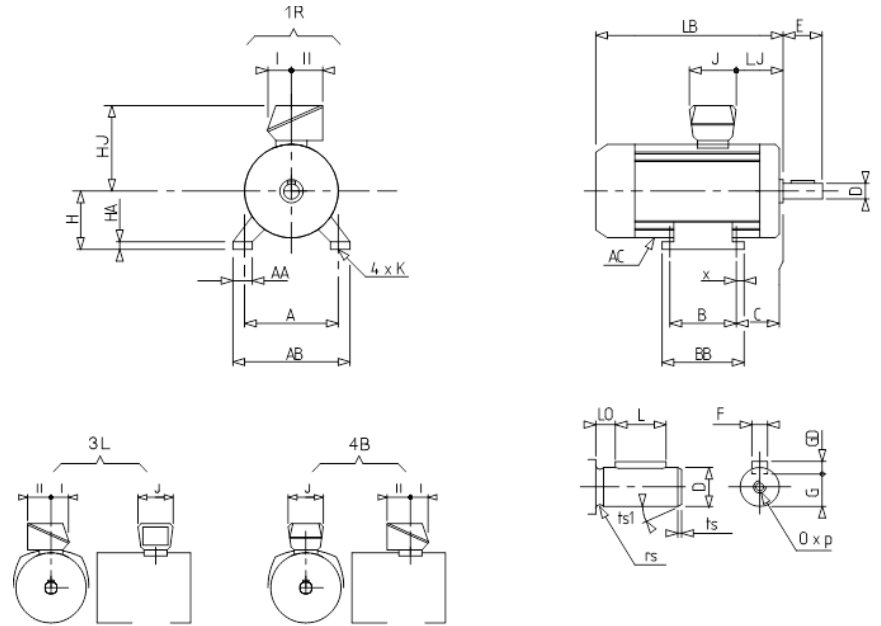

	SIEMENS
Tipo	Motor de anillos Rotor Bobinado
Modelo	1LT2176-8 AA20-ZB3
Num serie	1199944 y 1199941
Potencia	15% 35KW 220/380v 135/78amp 25% 30KW 220/380v 118/68amp 40% 2,5KW 220/380v 100/58amp
Frecuencia	50hz
Rotor	15% 270V 82amp 25% 270V 70amp 40% 270V 58amp
Tamaño	225
Eje principal	Conico 50-60 mm x 110 + 30rosca
Eje trasero	Conico 42,5-50 mm x 80 + 30rosca
Aislamiento	B1
Configuracion	Patas B3